

POWER MANAGEMENT

Low Power, 3.3V/3.0V μ P Reset - Active HIGH, Push-Pull Output

The IMP1817 supply voltage monitor is an improved, low-power replacement for the Dallas Semiconductor DS1817. Maximum supply current over temperature is a low 15 μ A, representing over 50 percent lower power as compared to the DS1817.

The IMP1817 issues an active HIGH reset signal whenever the monitored supply is out-of-tolerance. A precision reference and comparator circuit monitor power supply (V_{CC}) level. Tolerance level options are 5-, 10- and 20-percent. When an out-of-tolerance condition is detected, an internal power-fail signal is generated which forces an active HIGH reset signal. After V_{CC} returns to an in-tolerance condition, the reset signal remains active for 150ms to allow the power supply and system microprocessor to stabilize.

The IMP1817 is designed with a push-pull output stage and operates over the extended industrial temperature range. Devices are available in compact surface mount SOT-23 packages and 3-lead TO-92 packages.

Other low power products in this family include the IMP1810/11/12/15/16, IMP1233D and IMP1233M.

Family Selection Guide

Part	RESET Voltage (V)	RESET Time (ms)	Output Stage	RESET Polarity
IMP1810	4.620, 4.370, 4.120	150	Push-Pull	LOW
IMP1811	4.620, 4.350, 4.130	150	Open-Drain	LOW
IMP1812	4.620, 4.350, 4.130	150	Push-Pull	HIGH
IMP1815	3.060, 2.880, 2.550	150	Push-Pull	LOW
IMP1816	3.060, 2.880, 2.550	150	Open-Drain	LOW
IMP1817	3.060, 2.880, 2.550	150	Push-Pull	HIGH
IMP1233D	4.625, 4.375, 4.125	350	Open-Drain	LOW
IMP1233M	4.625, 4.375, 2.720	350	Open-Drain	LOW

Block Diagram

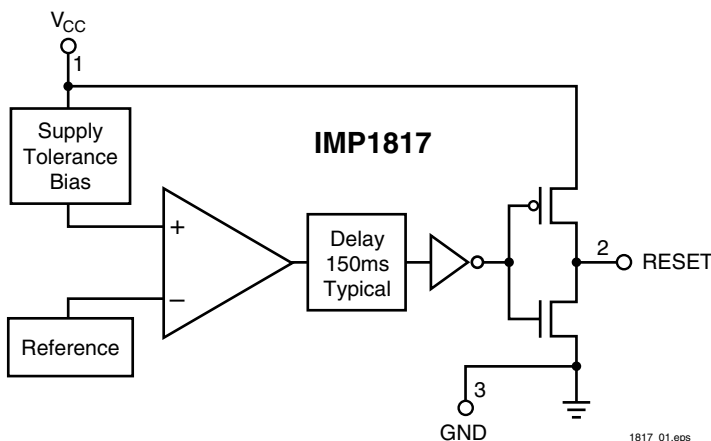

Key Features

- ◆ Improved Dallas DS1817 replacement
 - Over 50% lower maximum supply current
- ◆ Low Supply Current
 - 20 μ A maximum (5.5V)
 - 15 μ A maximum (3.6V)
- ◆ Automatically restarts a microprocessor after power failure
- ◆ 150ms reset delay after V_{CC} returns to an in-tolerance condition
- ◆ Active HIGH power-up reset
- ◆ Precision temperature-compensated voltage reference and comparator
- ◆ Eliminates external components
- ◆ Low-cost TO-92 package
- ◆ Compact surface mount SOT-23 package
- ◆ Push-Pull output for minimum current drain
- ◆ Operating temperature -40°C to $+85^{\circ}\text{C}$

Applications

- ◆ Set-top boxes
- ◆ Cellular phones
- ◆ PDAs
- ◆ Energy management systems
- ◆ Embedded control systems
- ◆ Printers
- ◆ Single board computers

Typical Application

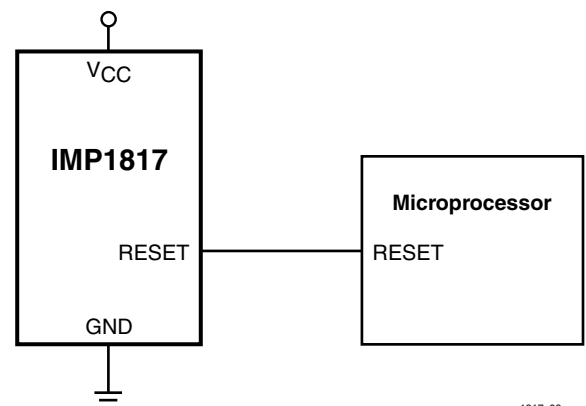

Pin Configuration

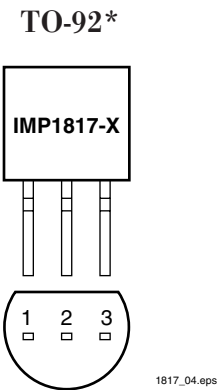
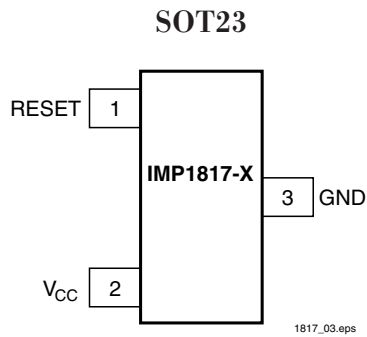

Pin Descriptions

Pin Number	Name	Function
1	RESET	Active LOW reset output
2	V _{CC}	Power supply input
3	GND	Ground

Package Marking Code

SOT-23 Package Letter Code			
A	B	Part	Reset Tolerance
M	A	IMP1817	5%
M	B	IMP1817	10%
M	C	IMP1817	20%

1817_102.eps

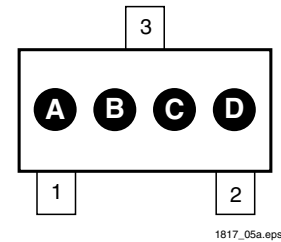

Ordering Information

Device Summary								Package Marking			
Part**	RESET Output Voltage (V)	RESET Tolerance (%)	RESET Time (ms)	Push-Pull Output Stage	TO-92* Package	SOT-23 Package	RESET Polarity	A	B	C	D
IMP1817-5	3.06	5	150	●	●		LOW				
IMP1817-10	2.88	10	150	●	●		LOW				
IMP1817-20	2.55	20	150	●	●		LOW				
IMP1817R-5	3.06	5	150	●		●	LOW	M	A	X	X
IMP1817R-10	2.88	10	150	●		●	LOW	M	B	X	X
IMP1817R-20	2.55	20	150	●		●	LOW	M	C	X	X

* Add /S to Part Number for straight (unformed) leads. (ie. IMP18xx-x/S)

** Add /T to Part Number for Tape and Reel. (ie. IMP18xx-x/T)

XX = Date code

Absolute Maximum Ratings

Voltage on V_{CC} -0.5V to 7V
 Voltage on RESET -0.5V to $V_{CC} + 0.5V$
 Operating Temperature Range -40°C to 85°C

Soldering Temperature 260°C for 10 seconds
 Storage Temperature -55°C to 125°C

*Voltages measured with respect to ground.
 These are stress ratings only and functional operation is not implied.*

Electrical Characteristics

Unless otherwise noted, $V_{CC} = 1.2V$ to $5.5V$ and specifications are over the operating temperature range of -40°C to +85°C.
 All voltages are referenced to ground.

Parameter	Symbol	Conditions	Min	Typ	Max	Units
Supply Voltage	V_{CC}		1.2		5.5	V
Output Voltage	V_{OH}	$I_{OUT} < 500\mu A$	$V_{CC} - 0.5V$	$V_{CC} - 0.1V$		V
Output Current	I_{OH}	Output = 2.4V, $V_{CC} \geq 2.7V$		350		μA
Output Current	I_{OL}	Output = 0.4V, $V_{CC} \geq 2.7V$	+10			mA
Operating Current	I_{CC}	$V_{CC} < 5.5V$, RESET output open		8	20	μA
Operating Current	I_{CC}	$V_{CC} \leq 3.6V$, RESET output open		6	15	μA
V_{CC} Trip Point (IMP1817-5)	V_{CCTP}		2.98	3.06	3.15	V
V_{CC} Trip Point (IMP1817-10)	V_{CCTP}		2.80	2.88	2.97	V
V_{CC} Trip Point (IMP1817-20)	V_{CCTP}		2.47	2.55	2.64	V
Output Capacitance	C_{OUT}				10	pF
V_{CC} Detect to RESET Low	t_{RPD}			2	5	μs
V_{CC} Slew Rate (V_{CCTP} (MAX) to V_{CCTP} (MIN))	t_F	Note 1	300			μs
V_{CC} Slew Rate (V_{CCTP} (MIN) to V_{CCTP} (MAX))	t_R		0			ns
V_{CC} Detect to RESET High	t_{RPU}	$t_R = 5\mu s$	100	150	250	ms

Notes 1. The t_F value is for reference in defining values for t_{RPD} and should not be considered a requirement for proper operation or use.

Application Information

Operation – Power Monitor

The IMP1817 detects out-of-tolerance power supply conditions. It resets a processor during power-up, power-down and issues a reset to the system processor when the monitored power supply voltage is below the reset threshold. When an out-of-tolerance V_{CC} voltage is detected, the RESET signal is asserted. On power-up, RESET is kept active (HIGH) for approximately 150ms after the power supply voltage has reached the selected tolerance. This allows the power supply and microprocessor to stabilize before RESET is released.

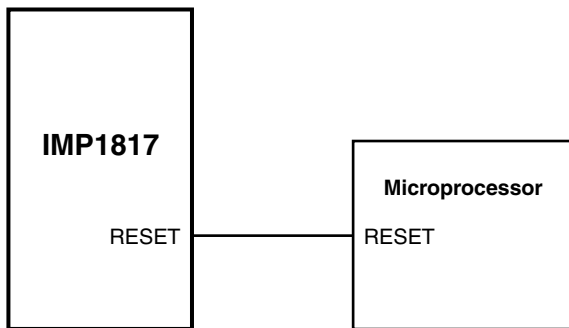

1815_07.eps

Figure 1. RESET Valid to 0V V_{CC}

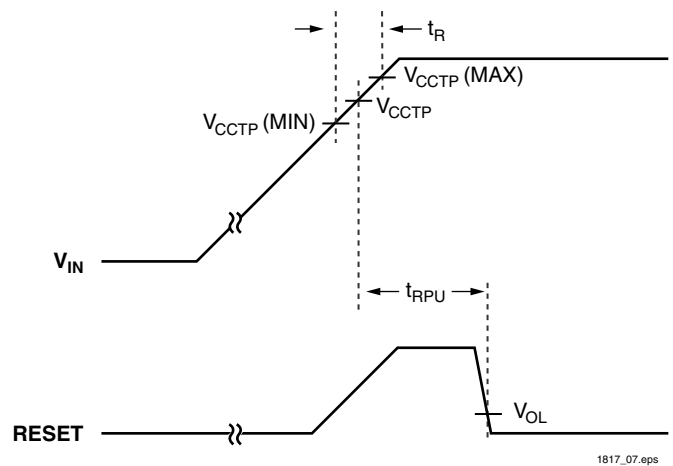

1817_07.eps

Figure 2. Timing Diagram: Power-Up

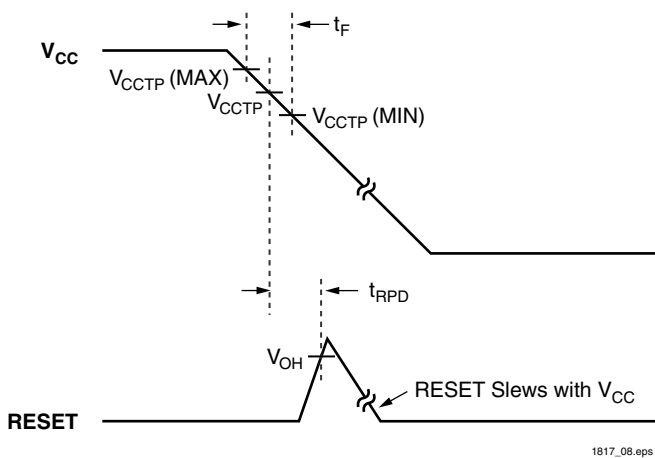

1817_08.eps

Figure 3. Timing Diagram: Power-Down

Package Dimensions

Plastic SOT-23 (3-Pin)

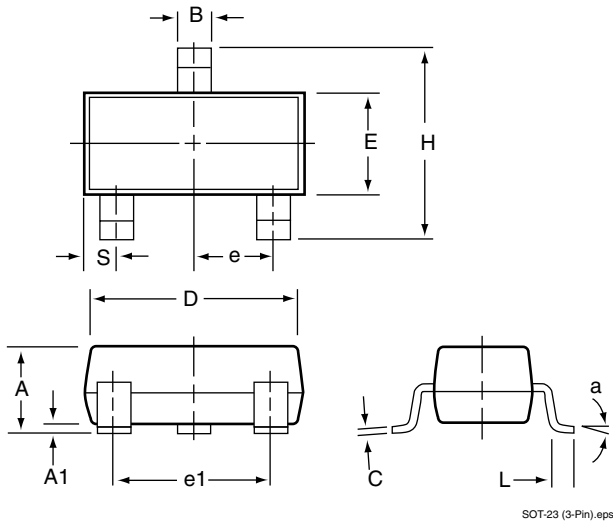

TO-92 (3-Pin)

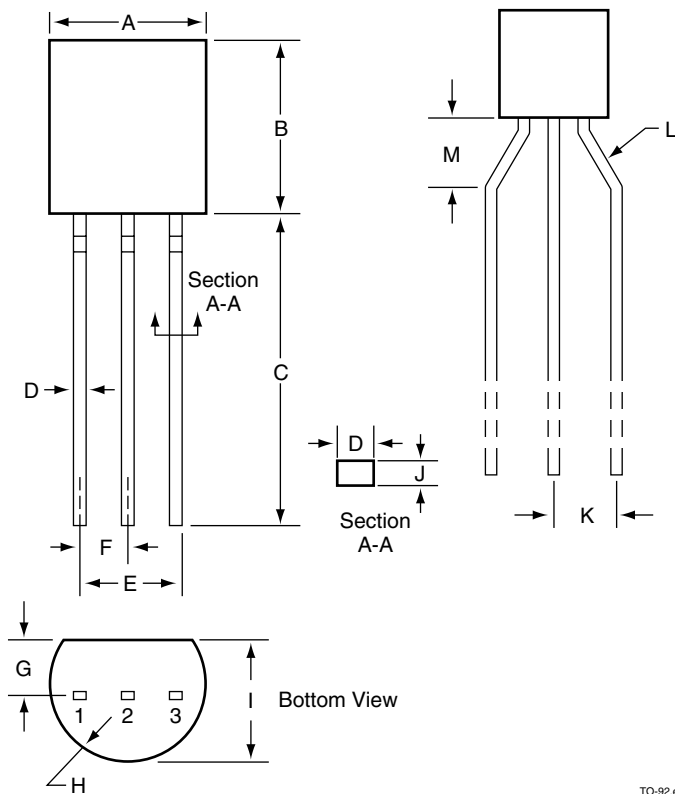

	Inches		Millimeters	
	Min	Max	Min	Max
Plastic SOT-23 (3-Pin)				
A	0.031	0.050	0.80	1.27
A1	0.004	0.010	0.10	0.25
B	0.015	0.020	0.37	0.51
C	0.003	0.007	0.085	0.18
D	0.110	0.120	2.80	3.04
E	0.047	0.055	1.20	1.40
e	0.035	0.040	0.89	1.03
e1	0.070	0.080	1.78	2.05
H	0.083	0.1039	2.10	2.64
L	0.027 REF		0.069 REF	
S	0.018	0.024	0.45	0.60
TO-92* (3-Pin)				
A	0.175	0.195	4.45	4.95
B	0.170	0.192	4.32	4.96
C	0.500	0.610	12.70	15.49
D	0.016	0.022	0.406	0.559
E	0.095	0.105	2.41	2.67
F	0.045	0.60	1.14	1.52
G	0.45	0.060	1.14	1.52
H	0.085	0.095	2.16	2.41
I	0.130	0.155	3.30	3.94
J	0.014	0.020	0.35	0.51
K	0.093	0.115	2.36	2.92
L	45°	60°	45°	60°
M	0.118 Typical		3.00	

* Formed leads are standard. Add /S to Part Number for straight leads.
(ie. IMP18xx-x/S)

1817_104.eps



IMP, Inc.
Corporate Headquarters
2830 N. First Street
San Jose, CA 95134-2071
Tel: 408-432-9100
Tel: 800-438-3722
Fax: 408-434-0335
e-mail: info@impinc.com
<http://www.impweb.com>

The IMP logo is a registered trademark of IMP, Inc.
All other company and product names are trademarks of their respective owners.

© 1999 IMP, Inc.
Printed in USA
Publication #: 1008
Revision: A
Issue Date: 06/16/99
Type: Preliminary